

# JET 24V SHEV systems for fire prevention

**VELUX®**
**Commercial**

Optimally designed for various applications

## JET 24V SHEV system

### Advantages of the 24V technology

- standby current controlled system
- visual and acoustical alarm and fault indicator
- priority circuit for all alarm-open-commands
- economical control of actual state (open/close/ventilation position)
- only one drive system for all opening positions

### Economic realization of all commands

- smoke detection/temperature detection
- alerting (internal/external)
- manual operation (alarm or ventilation)
- stepless ventilation
- wind and rain detector
- finishing time close-control
- connection to building management system (GLT/ZLT)



*JET dome rooflight  
with 24V telescope  
spindle drive*

### Possible functions

- electromotor-activated smoke exhaust opening
- smoke detector
- manually activated DIN SHEV switch
- external fire alarm system (BMA)
- external building management system (GLT/ZLT)
- ambient temperature control timer
- ventilation double switch
- wind and rain detector

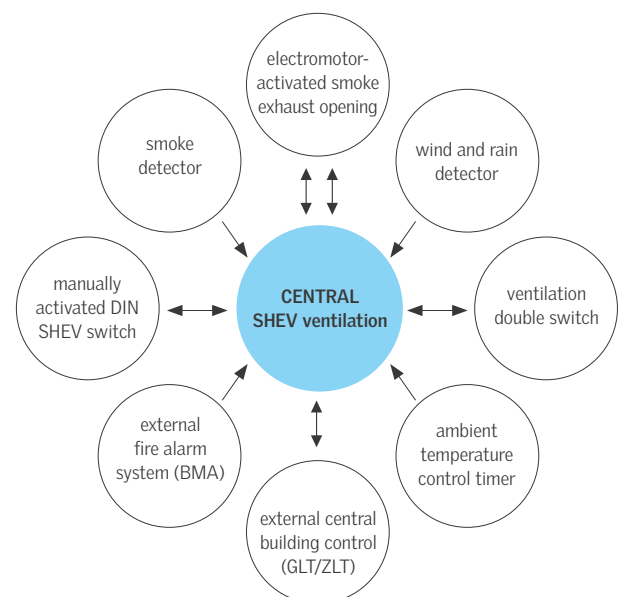

1.1.1  
JET TOP-90

1.1.2  
JET TOP-90 PLUS

1.1.3  
JET TOP-90  
sound reduction

3.4.2  
JET SKYSIGHT

3.5.2  
JET TOP-90  
comfort-S

3.6.2  
JET ISO pyramid 45°  
GLASS/GRILLODUR®

3.6.3  
JET ISO hip 45°  
GLASS/GRILLODUR®

## Smoke and heat exhaust systems are safety systems!

For fire prevention the question of functional reliability, from the planning stage to assembly and maintenance of the system, is of elementary importance. A specialist company certified by VdS can offer architects and building owners necessary assurance in this matter. The JET SHEV maintenance service

guarantees optimum functional reliability nationwide.

Please ask for the JET maintenance contract!

## The JET system smoke exhaust, ventilation and daylight in combination

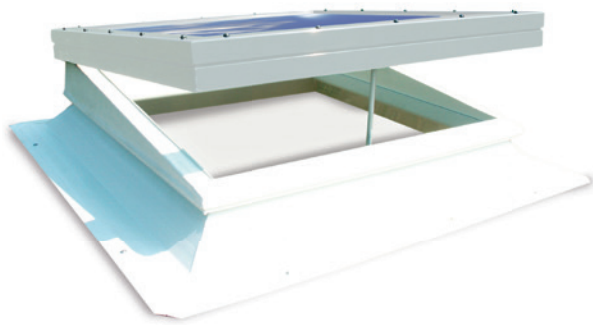











JET SKYSIGHT (with border frame) in ventilation position

Application possibilities of the JET 24V SHEV motor opener			Type of drive
Roof		glass roof ventilation flap roof-top window	Z, S, R, K
		dome rooflight	Z, S, R
		continuous rooflight flap	Z, S, R
		JET A products	Z, S, R, K
		JET SMOKEJET® surface ventilator	Z, S, R
Wall/facade		tilt/rotor window opening to the inside	K
		pivoting window	K
		tilt window opening to the outside at the top or bottom	K

Z: rack drive  
S: thrust spindle drive  
R: telescope spindle drive  
K: chain thrust drive

## The JET system: smoke exhaust, ventilation and daylight in combination

JET 24V motor drives		JET 24V SHEV centrals/switches/detectors/signaller	
 <p>JET motor opener with thrust spindle type M2</p>	<p>Thrust spindle drive</p> <ul style="list-style-type: none"> <li>• standard drive for JET dome rooflights and JET continuous rooflight flaps</li> <li>• 500N lifting force</li> <li>• integrated load shedding</li> <li>• thermal protection</li> <li>• potential-free contact for the open-indication</li> </ul>	 <p>JET SHEV central</p>	<ul style="list-style-type: none"> <li>• from the compact version for 2 drives up to large slide-in central unit for max. 48 drives and more</li> <li>• 72-hour backup power due to built in accumulators</li> <li>• motor, switch, BUS and smoke detector lines are standby current controlled</li> </ul>
 <p>JET telescope spindle drive type M8</p>	<p>Telescope spindle drive</p> <ul style="list-style-type: none"> <li>• for use in situations with high aesthetic requirements</li> <li>• with integrated electronic load shedding</li> <li>• 600N or 900N lifting force</li> </ul>	 <p>JET smoke exhaust switch</p>	<ul style="list-style-type: none"> <li>• lockable with glass panel for breaking in case of fire, available in orange, grey, yellow, blue and red</li> <li>• visual display for alarm and control</li> <li>• acoustic alarm and fault indicator</li> </ul>
 <p>JET telescope spindle drive type M8-S</p>	<p>Telescope spindle drive</p> <ul style="list-style-type: none"> <li>• for use in situations with high aesthetic requirements</li> <li>• with integrated electronic synchronous control</li> <li>• for the synchronous run of 2 drives</li> <li>• 900N lifting force</li> </ul>	 <p>JET ventilation rotary switch</p>	<ul style="list-style-type: none"> <li>• ventilation rotary switch with touch and latching function (adjustable)</li> <li>• available in upon or under plaster version</li> </ul>
 <p>for smaller dimensions JET motor opener with rigid chain type M3</p>	<p>chain thrust drives</p> <ul style="list-style-type: none"> <li>• elegant alternative to the spindle drives</li> <li>• can also be installed on narrow window cover frames due to low installation height</li> <li>• nearly all window types can be opened electrically by the use of suitable consoles</li> <li>• stroke length from 100 up to 800mm (depending on type of drive)</li> <li>• lifting force from 250 up to 1000N (depending on type of drive)</li> <li>• with integrated electronic load shedding</li> <li>• application as solo, tandem or synchronous drive (depending on type of drive)</li> <li>• operating parameters programmable (depending on type of drive)</li> </ul>	 <p>JET wind/rain detector</p>	<ul style="list-style-type: none"> <li>• in case of wind and rain the system is closed automatically</li> <li>• as soon as ventilation is possible again the system can be opened manually</li> <li>• wind on-delay and wind/rain delayed release adjustable</li> <li>• wind sensitivity adjustable</li> <li>• rain sensor heated</li> </ul>
 <p>for medium dimensions JET motor opener with rigid chain type KA</p>		 <p>JET smoke detector</p>	<ul style="list-style-type: none"> <li>• building approval</li> <li>• VdS-approval no.: G200017</li> <li>• smoke detection by scattered light principle</li> <li>• visual alarm display</li> </ul>
 <p>for larger dimensions and selected glass products JET motor opener KM13</p>	<p>various signallers for connection to the JET 24V SHEV</p>	<ul style="list-style-type: none"> <li>• flashlight for visual signalling after a SHEV release</li> <li>• alarm siren: warning with 115 dB (A) also suitable for outdoor installation</li> <li>• Piezo-buzzer: warning with 90 dB (A)</li> <li>• fire bell: warning with 86 dB (A)</li> </ul>	

## Sample: Wiring diagram for JET SHEV centrals

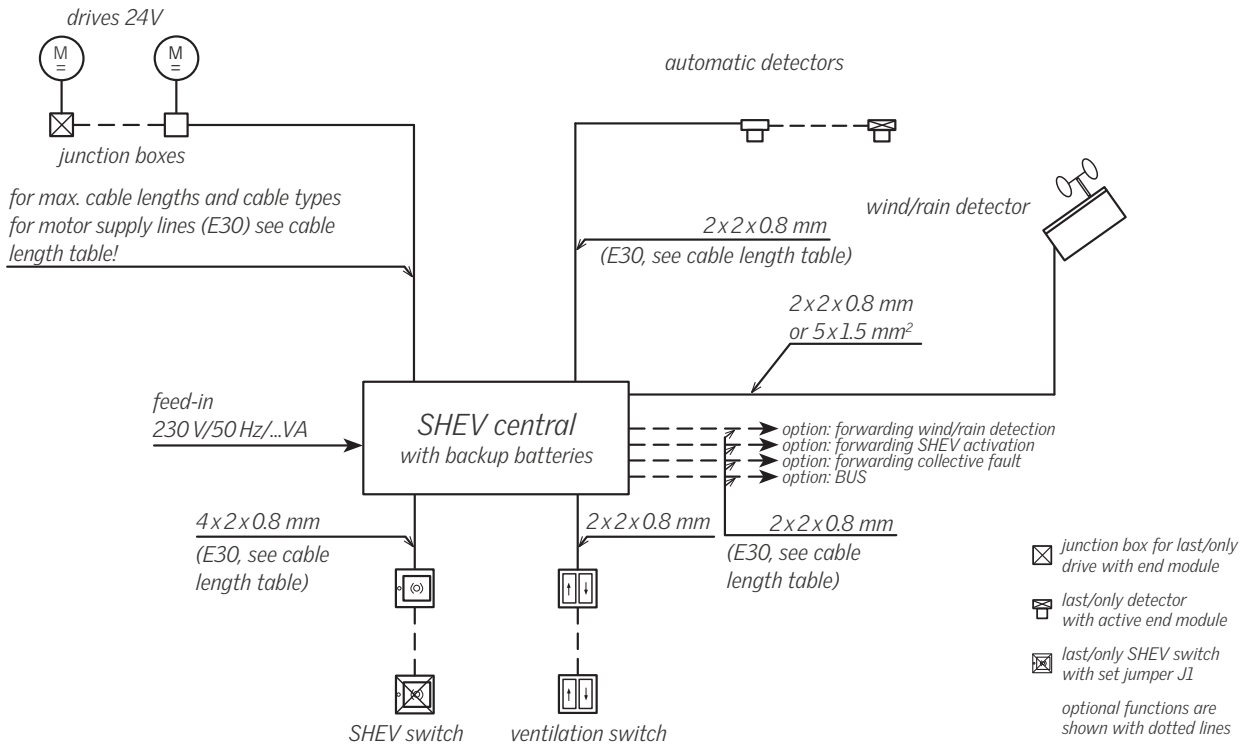

**Note:**  
Other JET SHEV central control units upon request

**Attention:**  
In case of the motor supply line it is not allowed to use the protective conducting wire (green/yellow)!  
Please consider the VDE guidelines!

## Maximum permitted cable lengths for the JET SHEV central control units in combination with standard drives taking into consideration the specified cable cross sections

Cross section drive current	3.0 x 1.5mm <sup>2</sup>	5.0 x 1.5mm <sup>2</sup>	3.0 x 2.5mm <sup>2</sup>	5.0 x 2.5mm <sup>2</sup>	3.0 x 4.0mm <sup>2</sup>
1 A	84m	168m	140m	280m	224m
2 A	42m	84m	70m	140m	112m
3 A	28m	56m	47m	93m	75m
4 A	21m	42m	35m	70m	56m

**Note:**  
Electrical wires must be laid according to the respective applicable version of the VDE guidelines in general.